

GENERAL NOTES:-
WEIGHT 15 Kg

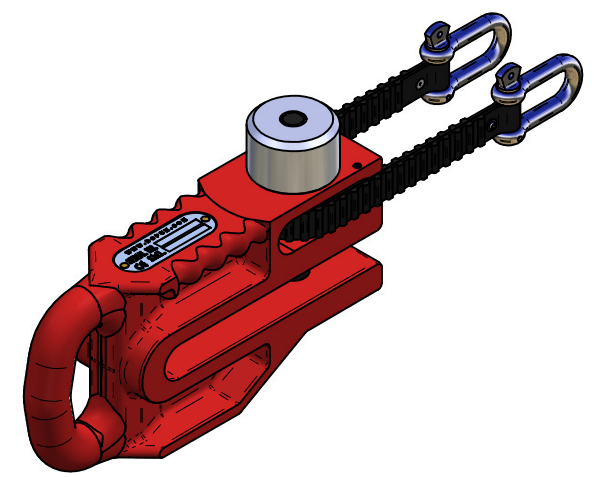

Ref.no.	Qnt.	Part name	Material	Dimension	Remark
19	1	GUIDE PEG	EN36	CASE HARDEN 1MM	672
18	1	5T THREADED PIN	655M13 EN36B		671
17	1	ERRS 5T 150 THROAT		026	662
16	1	PAWL SPRING	M4 MUSIC WIRE		628
15	1	PAWL	NYLON GSM		627
14	1	PIVOT PIN	EN58		626
13	4	DOG PT GRUB SCREW	M6x8		618
12	2	SPRING PIN	DIA 4 x 20		617
11	1	O-RING	200-223	4470	610
10	2	SMALL D SHACKLE			609
9	1	RATCHET BELT ASSY			608
8	1	NYLON BUFFER STOP	NYLON 66		607
7	1	NYLON RING	NYLON 66		606
6	1	RELEASE NUT	HE 30 TF		605
5	1	RATCHET COLLAR MACHINED	was RRS007	HDA44 6082 TF	604
4	1	SHACKLE ID PLATE	ALUMINIUM		5938
3	2	No6 x 1/2" Rivet			1204.000.01
2	1	SOC SET SCREW	M12x12		0M12.010.05
1	1	SOC SET SCREW	M6x6		0M06.006.05

SURFACE UNLESS S

▽ RC
▽▽ FI
▽▽▽ GRIND

N6

ANGLES +/- 0.5°
DIMENSIONS IN MILLIMETERS

Design by peter watts	Drawn by peter watts	Copied -	Checked -	Standard A3	Affirmed -	Scale -	Replace -	Replaced by -
DAWSON CONSTRUCTION PLANT LTD.						5T ERRS 150 THROAT GENERAL ASSEMBLY		Sheet 1 of 1 Drawing no.
						Date 18/04/2007 683		